

Direct current dimmable (TRAILING EDGE-LEADING EDGE) electronic drivers with DIP-SWITCH  
Alimentatori elettronici regolabili (IGBT-TRIAC) in corrente continua con DIP-SWITCH

Made in Europe



**SELV**



## 3.1

Dimmable multipower LED drivers  
Alimentatori LED multipotenza regolabili



**Rated Voltage**  
Tensione Nominale  
220 ÷ 240 V

**Frequency**  
Frequenza  
50...60 Hz

**AC Operation range**  
Tensione di utilizzo AC  
198 ÷ 264 V

**DC Operation range**  
Tensione di utilizzo DC  
176 ÷ 264 V  
(NO IGBT/TRIAC)  
(NO PUSH mode function)

**Power**  
Potenza  
0 ÷ 32 W

**Maximum current output ripple**  
Max. ondulazione della corrente uscita  
≤ 3%<sup>(1)</sup>

**Reference Norms**  
Norme di riferimento:  
EN 50172 (VDE 0108)  
EN 55015  
EN 61000-3-2  
EN 61000-3-3  
EN 61347-1  
EN 61347-2-13  
EN 61547  
EN 62384  
VDE 0710-T14

**Lamps**  
Lampade:  
Power LED  
LED modules

Article Articolo	Code Codice	P out W	V out DC	I out DC	n° LED max. <sup>(1)</sup>	V out max.	ta °C	tc °C	λ max. Power Factor	η max. Efficiency <sup>(1)</sup>			
<b>DC JOLLY MD</b>	122260	<b>Constant current output - Uscita in corrente costante</b>						75	0,97	>85			
		17	47 max.	350 mA cost.	12	55	-25...+50						
		24	47 max.	500 mA cost.	12								
		25	47 max.	550 mA cost.	12								
		32	46 max.	700 mA cost.	12		-25...+45						
		32	43 max.	750 mA cost.	11/12								
		<b>Constant voltage output - Uscita in tensione costante</b>											
		10	12 cost.	900 mA max.	-	-	-25...+50						
		20	24 cost.	900 mA max.	-	-							
		22	28 cost.	900 mA max.	-	-							

<sup>(1)</sup> Referred to  $V_{in} = 230$  V, 100% load - Riferito a  $V_{in} = 230$  V, carico 100%

Accessories not supplied - Accessori non a corredo		
Article - Articolo	L (length)	Code - Codice
Synchronization cable Cavetto di sincronizzazione	1,5 m / 4 ft	485720512
	4 m / 13 ft	485720513
	50 cm / 19,68"	485720515
	20 cm / 7,87"	485720516
DCC DALI INTERFACE (pag. 280)		122099
BMU DMX INTERFACE (pag. 282)		122066

### Features

- Multipower driver supplied with dip-switch for the selection of the output current.
- IP20 independent driver, for indoor use.
- Class II protection against electric shock for direct or indirect contact.
- Active Power Factor Corrector.
- Current regulation ±5 % including temperature variations.
- Input and output terminal blocks on opposite sides (wire cross-section up to 2,5 mm<sup>2</sup> / AWG13).
- Clamping screws on primary and secondary circuits for cables with diameter: min. 3 mm - max. 8 mm.
- Double terminal blocks to loop other driver.
- Protections:
  - against overheating and short circuits;
  - against mains voltage spikes;
  - against overloads.
- Thermal protection = C.5.a.

### Caratteristiche

- Alimentatore multipotenza fornito di dip-switch per la selezione della corrente in uscita.
- Alimentatore indipendente IP20, per uso interno.
- Protetto in classe II contro le scosse elettriche per contatti diretti e indiretti.
- PFC attivo.
- Corrente regolata ±5 % incluse variazioni di temperatura.
- Morsetti di entrata e uscita contrapposti (sezione cavo fino a 2,5 mm<sup>2</sup> / AWG13).
- Serracavo su primario e secondario per cavi di diametro: min. 3 mm - max. 8 mm.
- Doppia morsettiera lato rete per rimando ad altro alimentatore.
- Protezioni:
  - termica e cortocircuito;
  - contro le extra-tensioni di rete;
  - contro i sovraccarichi.
- Protezione termica = C.5.a.





Weight - Peso: gr. 185 / 6,52 oz.  
 Pcs - Pezzi 40

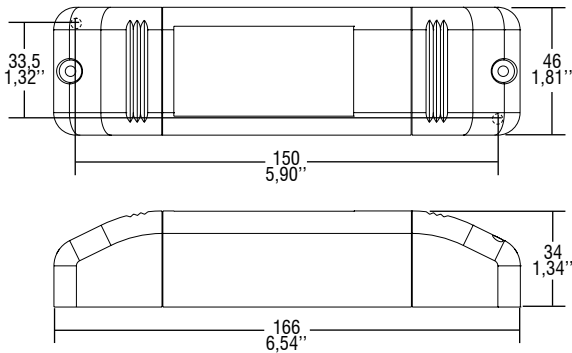

**Wiring diagram - Schema di collegamento** (Max. LED distance on page info8 - Massima distanza LED a pagina info8)

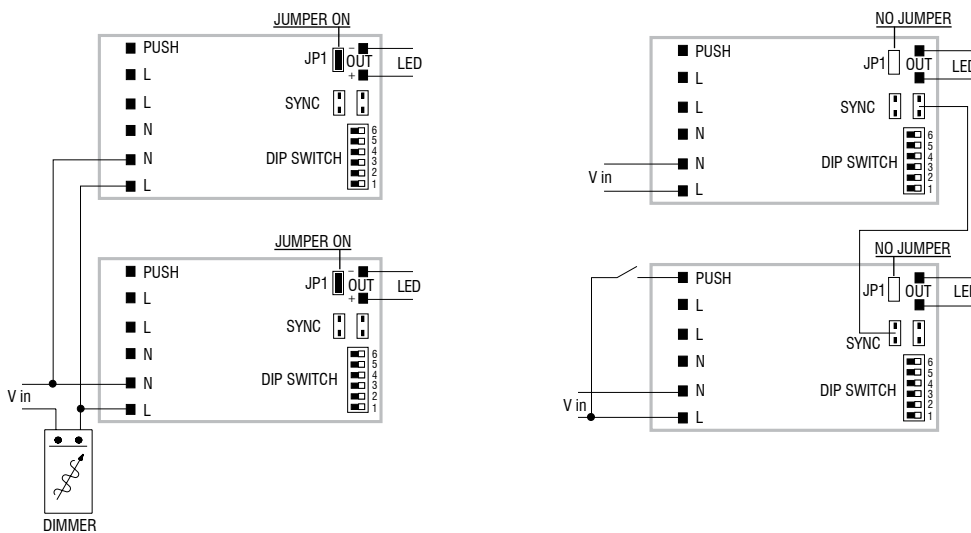

**PHASE-OUT dimming** - To avoid flickering, keep the slaves at 100% dimming level.  
 Dimmerazione FASE-OUT - Per evitare flicker, i singoli slaves devono essere lasciati con dimming 100%.

**PUSH diagram - Collegamento PUSH**

**Operation Mode**

- Regulating driver with "phase cut-off" dimmer IGBT, TRIAC and PUSH.
- Light regulation 0/0,5 - 100 % by means of PUSH function (mains voltage):
  - a short push to turn on and off;
  - a longer push to increase or decrease light intensity;
  - regulation automatically stops at minimum and maximum values;
  - for another on, regulation or off command, release the push button and give the desired command again;
  - dimming level memory at mains restore.
- Maximum length of the cable, from push button to last transformer, must be max. 15 m / 49 ft. In case of applications where the cable is longer than 15 m / 49 ft, keep this separate from the 220 - 240 Volt mains cable.
- **ATTENTION:** only use normally open push buttons with no incorporated warning light.
- Max. 10 synchronised drivers of which only one can be controlled (1 Master + 9 Slaves).
- Synchronization cable is separately supplied.

For additional details for regulations see pages info12-14.

**Modalità di funzionamento**

- Alimentatore regolabile con dimmer a "taglio di fase" IGBT, TRIAC e PUSH.
  - Regolazione della luminosità 0/0,5 - 100 % mediante la funzione PUSH (tensione di rete):
    - una pressione breve per accendere e spegnere;
    - una pressione prolungata per aumentare o diminuire l'intensità luminosa;
    - la regolazione si ferma automaticamente ai valori minimi e massimi;
    - per un nuovo comando accensione, regolazione o spegnimento, rilasciare il pulsante e dare nuovamente il comando desiderato;
    - ripristino del livello di dimming al ritorno alimentazione.
  - La lunghezza massima del cavo, dal pulsante all'ultimo trasformatore, deve essere max. 15 m / 49 ft. In caso di applicazioni dove il cavo superi i 15 m / 49 ft, tenere lo stesso separato dal cavo di rete 220 - 240 V.
  - **ATTENZIONE:** usare solo pulsanti di tipo normalmente aperto privi di spia luminosa incorporata.
  - Max. 10 alimentatori sincronizzati, di cui uno solo comandato da uno o più punti (1 Master + 9 Slaves).
  - Cavetto per la sincronizzazione fornito separatamente.
- Per ulteriori dettagli sulle regolazioni vedi pagine info12-14.